

AUTHORIZING AN ARCHITECTURAL IMPROVEMENT PROGRAM (AIP) ECONOMIC INCENTIVE FOR THE EGYPTIAN THEATER, 135 N. SECOND STREET, DEKALB, ILLINOIS IN THE AMOUNT OF \$4,314.

WHEREAS, the City of DeKalb (the "City") is a home rule unit pursuant to Article VII, Section 6(a) of the 1970 Illinois Constitution and may exercise any power and perform any function pertaining to its government and affairs; and

WHEREAS, the City has previously created the Architectural Improvement Program (AIP) Grant process and seeks to approve of an AIP Grant for the Egyptian Theatre for the property located at 135 N. Second Street, DeKalb, Illinois in the amount of \$4,314.00.

NOW, THEREFORE, BE IT RESOLVED BY THE COUNCIL OF THE CITY OF DEKALB, ILLINOIS:

SECTION 1: The City of DeKalb approves an AIP Grant in the amount of \$4,314.00 for the Egyptian Theatre (the "Owner") for use at the property located at 135 N. Second Street, DeKalb, Illinois ("the Property"), subject to the following provisions:

1. Given the small scope of the requested grant, the City waives formal compliance with the requirements of the AIP process except as outlined herein. The City also waives requirement of a promissory note or mortgage to secure the AIP Grant.
2. Payment of the AIP Grant shall be as a reimbursement to Owner, after Owner provides proof of incurring costs of not less than \$8,628.00 on renovation at the Property consisting of: Americans with Disabilities Act (ADA) compliance on the stage access wheelchair lift. The AIP Grant shall be in the amount which is the lesser of: a) \$4,314.00; or b) the amount which is not more than 50% of the total project costs.
3. The Owner agrees to provide documentation of the project and incurred costs, inclusive of full lien waivers, invoices, and adequate evidence of payment, all in form and content acceptable to the City Manager or designee, prior to payment of the reimbursement.
4. The Owner agrees, as a condition of accepting the funds contemplated herein, to maintain the improvements funded by this AIP Grant for a period of not less than five (5) years. The AIP Grant funds provided herein shall be considered partially forgiven by 20% (1/5) each year on the anniversary of their payment to Owner, until fully forgiven on the fifth anniversary of such payment. Should Owner fail to maintain the improvements for the full five-year period, then Owner shall be responsible for reimbursing the City in an amount equivalent to the then-unforgiven portion of the AIP Grant (e.g., if the Owner fails to maintain the improvements in the 4th year, the Owner shall reimburse the City for forty percent (40%) of the AIP Grant amount.
5. The Owner agrees to indemnify, defend, and hold harmless the City from any claims or damages arising out of or relating to the AIP Grant or the work to be performed by Owner. The Owner shall provide the City with a certificate of insurance naming the City as additional primary insured with waiver of right of subrogation prior to commencement of work. The Owner agrees and acknowledges that the funding contemplated herein is payable to Owner only and may not be assigned or transferred to any other party. The City shall not make direct payments

to any contractors or materialmen, and the City's obligation to provide funding shall not accrue until Owner provides the City with evidence of lien waivers from all contractors and materialmen providing labor or materials for the project.

6. The Owner shall complete all related work in a good and workmanlike fashion, in accordance with all applicable codes and ordinances, and after having obtained all required permits. All work shall be subject to inspection and approval by the City, once completed.
7. All work shall be completed within one calendar year of the date of approval of this Resolution, or the funding approval contemplated herein shall terminate and this Resolution shall be of no further force or effect.
8. Owner shall provide a letter to the City, acknowledging and agreeing to the terms and conditions of this Resolution, prior to the City's issuance of payment to Owner.

SECTION 2: The City Clerk or the Executive Assistant shall be authorized and directed to attest the Mayor's Signature and shall be effective thereupon, following execution as outlined in the preceding section.

PASSED BY THE CITY COUNCIL of the City of DeKalb, Illinois at a Regular meeting thereof held on the 8th day of March 2021 and approved by me as Mayor on the same day. Passed by an 8-0 roll call vote. Aye: Morris, Finucane (Remote), Smith, Perkins, McAdams, Verbic, Faivre, Mayor Smith. Nay: None.

ATTEST:



RUTH A. SCOTT, Executive Assistant

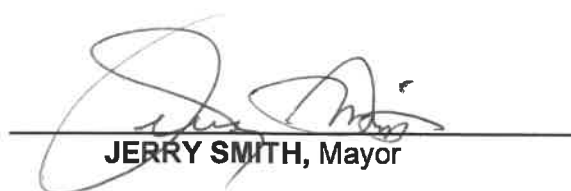

JERRY SMITH, Mayor





164 East Lincoln Highway
DeKalb, Illinois 60115
815.748.2000 • cityofdekalb.com

Architectural Improvement Program Application

Name: Preservation of Egyptian Theatre, Inc.

Home Address: 135 N. 2nd Street, DeKalb, IL 60115

Property Identification Number (PIN): 08-23-158-041

Location of Property: 135 N. 2nd Street, DeKalb, IL 60115

Phone Number: 815-758-1215 Email: alex@egyptiantheatre.org

Proposed Use of Funding:

Major Capital Improvements – 50% Reimbursement

- ADA Compliance
- Façade Renovations
- Tuckpointing
- Life Safety Equipment
- Electrical, Mechanical, and Plumbing Upgrades
- Architectural Design Fees
- Restoration of Historic Architectural Features
- Fire Alarm and Suppression Systems

Minor Capital Improvements – 25% Reimbursement

- Exterior Lighting
- Window & Door Replacement
- Screening of Unsightly Utilities
- Exterior Painting

Deferred Maintenance – 10% Reimbursement

- Roof Repair or Replacement
- Gutter Replacement
- Stair and Handrail Replacement
- Floor Surface Repair
- Water Damage Repair

Have you consulted with the City about your project? Yes No
If yes, with whom did you speak? Bill Nicklas

Total cost estimate of Project: \$8,628.00

Matching funds requested: \$4,314.00
(up to a maximum of \$25,000)

How long has the property been owned by you? 43 years

Project Description

In 250 words or less, please describe the scope of the project improvement and the need.

Please see attached.

Applicant(s) Alex Nerad

Alex Nerad - Executive Director

Date: 2-18-21





City of DeKalb
164 East Lincoln Hwy
DeKalb, IL 60115

February 18, 2021

City Manager Bill Nicklas,

I am contacting you to request AIA funding support for a sudden and unexpected project regarding ADA accessibility at the Egyptian Theatre.

On December 10, 2020 an elevator inspector from the State Fire Marshall office stopped by the Egyptian Theatre unannounced to look at our wheelchair lift that goes from our main floor up to the stage (roughly 4 feet). This lift has been here since 1998 serving performers and guests in wheelchairs that need access to the stage.

Despite being registered with the State of Illinois as required and passing previous inspections, the inspector condemned the lift and tagged it out of service. His reasoning was because he said this lift no longer meets the commercial building code requirements for wheelchair lifts. After multiple attempts of asking for it to be grandfathered or to request a variance, no flexibility was provided.

We inquired with multiple companies about modifying the lift to meet the code he was requiring us to meet and they all said it couldn't be done with this lift.

Our only options at this point is to replace the lift or go without a lift which would prohibit multiple individuals a year from accessing the stage. We talked with an architect and there is not enough room anywhere near the stage to install a wheelchair ramp nor are there any other locations around the stage to install a different wheelchair lift.

The only option to still provide wheelchair access to the stage, which is our priority, is to purchase a commercial portable wheelchair lift. After much research, we found two companies that make these lifts.

AmeriGlide Hercules 750 Portable (with delivery) \$8,628.00

Ascension Protégé Lift 5442 P (with delivery) \$23,636.00

Ascension Virtuoso 5460 P (with delivery) \$30,998.50

Our desire is to purchase the AmeriGlide Hercules unit for \$8,628.00.

EGYPTIAN THEATRE
135 N 2ND STREET - DEKALB, IL 60115
WWW.EGYPTIANTHEATRE.ORG

As you are aware, we were closed March 13, 2020 due to the COVID-19 mitigation efforts in the State of Illinois. We were allowed to reopen in October 2020 with extremely limited capacity and then closed down again in November 2020 by the State. Late January 2021 we were allowed to open again with extremely limited capacity. This has allowed us to host some ticketed tours, movies, and private events.

For March-December 2020 our estimated loss in revenue was \$600,000. Thus far, we have been fortunate to receive a number of COVID relief grants and donations from the community. Every month has been a challenge financially to keep the lights on. While things are looking more optimistic, it is still estimated that things for our industry won't return to "normal" until 2022. We have continued to cut every expense we can while applying for grants and fundraising to sustain operations.

Also, in 2020, we completed our expansion project that started May 1, 2019 and was generously supported by the City of DeKalb and the community. Due to many unknown surprises during the construction project on this 90+ year old building and very much due to the dramatic impact of COVID-19, the project ended over budget. The complete project totaled \$6.5 million. We have about \$400,000 of that amount that we are continuing to fundraise for and apply for grants.

As a result of all of these circumstances, we are not in the financial position to replace the wheelchair lift to the stage as is being required by the State of Illinois. We would like to ask the City of DeKalb for an AIA grant in the amount of \$4,314.00 in order to purchase a new wheelchair lift. We are exploring other grant opportunities to cover the other 50% that the AIA grant won't cover.

Please let me know what questions you have. We appreciate your consideration.

Sincerely,



Alex Nerad
Executive Director
Preservation of Egyptian Theatre, Inc.
a 501(c)(3) non-profit organization

EGYPTIAN THEATRE
135 N 2ND STREET - DEKALB, IL 60115
WWW.EGYPTIANTHEATRE.ORG

5110 Atlantic Ave.
 Raleigh, NC 27616
 1 (800) 790-1635



Sales Quotation #31247

For Egyptian Theatre
Created 2/18/21
Good Through 4/19/21
Prepared By Taylor Vandiver

Item	Qty	Price	Ext.
AmeriGlide Hercules 750 Portable	1	\$8,628.00	\$8,628.00
Portable Option for Hercules DC 750 Includes			
455 Keys		incl.	
Rocker Switch		incl.	
Audible Emergency Alarm		incl.	
Pit Switch		incl.	
AC Power Cord and Interlock Wiring Kit (Interlocks Not Included)		incl.	
Two Platform Gates - Interlocks Included		incl.	
Two Call Stations Fixed on the Tower		incl.	
Power Source			
DC Battery Powered (2 x U1 Batteries Included)		incl.	
Lifting Height			
64" Maximum Lift Height		incl.	
Color of Unit			
Grey (standard)		incl.	
Platform / Tower Configuration			
Straight Thru Left Hand		incl.	
Platform Dimensions (Dimensions are All Clear)			
36" x 54"		incl.	
Lower Landing Orientation			
Open on Left		incl.	
Upper Landing Orientation			
Open on Left		incl.	
Delivery Options			

Item	Qty	Price	Ext.
Site Shipping - Customer Provided Fork Lift OR Loading Dock on Site	incl.		
Delivery State			
Illinois			\$1,129.00

Note: * Taylor Vandiver 800-580-0831 ext: 7509 *****

Item Total	\$8,628.00
Est. Tax	\$0.00
Shipping	\$0.00
Total	\$8,628.00

if clicking buy now does not work, copy and paste or type the following into your browser:
<http://www.ameriglide.com/redeemQuote.htm?q=17SA089286IFXDZY>

Buy Now

DRAWING FOR APPROBATION	
CHOOSER	APPROVED
(✓)	APPROVED AS NOTED
	RESUBMIT AS NOTED
SIGNATURE	DATE
SIGN AND RETURNED	

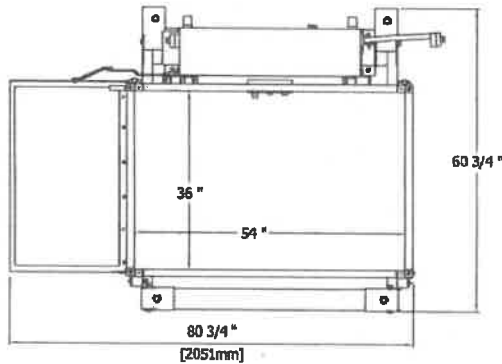

TOP VIEW

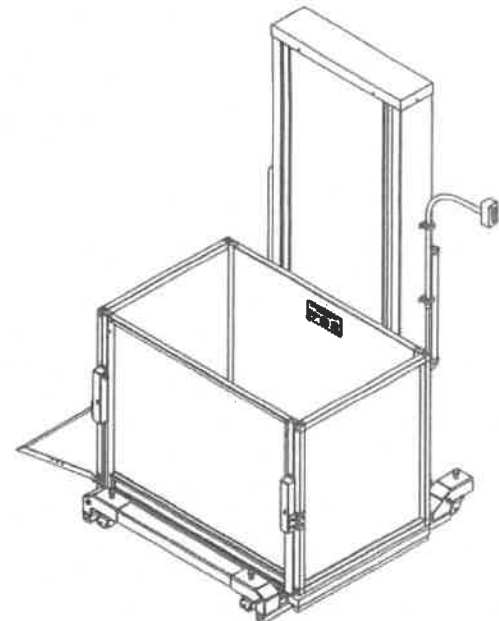

ISOMETRIC VIEW

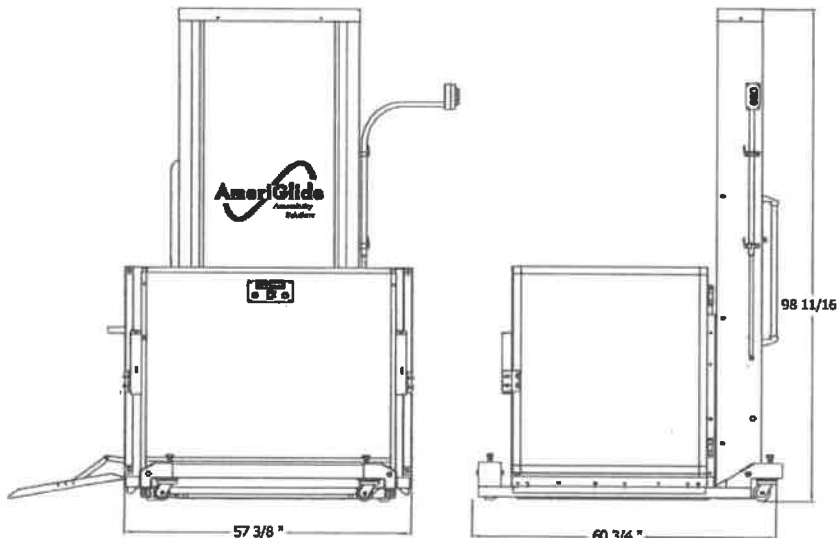
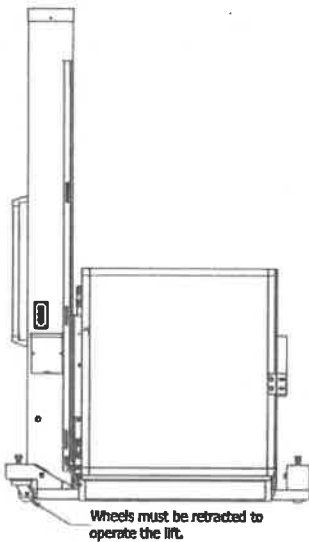

ELEVATION

*However the stage lifts for disabled peoples are not included in the scope the hereby mentioned codes; the components and the design of the device comply with the state of the art found in CSA B355-09, ASME A18.1 and ASME A17.1/CSA B44.

- SPECIFICATIONS**
- Capacity: 750 Lb
 - Travel: 8" à 64"
 - Motor: 1hp, 24 volts DC
 - 120V 20A
 - Power requirement :120volts AC, 20A
- *Specifications subject to changed without notice

1 PORTABLE VPL

AmeriGlide
Accessibility Solutions

AMERIGLIDE
5110 Atlantic Ave,
Raleigh, NC 27616
Tel:1 (800) 790-1635

www.ameriglide.com		REF: 2429-YA-A-210218		Code: B-355 2015 A18.1 2014	KONE ALLEGIANT STADIUM			
AMERIGLIDE IS NOT RESPONSIBLE FOR THE STRUCTURAL DESIGN OF THE BUILDING AND ITS ABILITY TO SUPPORT THE ELEVATOR LOADS AND OR REACTIONS		ALL DRAWINGS ARE THE INTELLECTUAL PROPERTY OF AMERIGLIDE AND CANNOT BE COPIED OR MODIFIED WITHOUT PERMISSION		GUARD PANEL: 42" HEIGHT		No DRAWING: HERCULES PORTABLE 36x54		
REV	MD	XXXX	MM-YY-2020	SCALE: ± 1/16"	Drafter: M. Debusschere	Date: 02-18-2021	Status: APPROVAL	Rev: 0
	BY	DESCRIPTION:	DATE:					1/2

GENERAL SPECIFICATIONS

- MODEL:** HERCULES PORTABLES
- CONFIGURATION:** 180 degree
- PLATFORM SIZE:** 36"W x 54"D
- FINISH:** Painted steel beige Standard (RAL 7047)
- CAPACITY:** 750 Lb
- CONTROL:** Constant pressure rocker switch with e-stop
- POWER SOURCE:** 120V 60Hz, 20Amp circuit (Power transformer)
- MOTOR:** 1 hp, 24VDC motor
- DRIVE SYSTEM:** Acme screw 1"Ø 5TPI
- SPEED:** 12 fpm
- LIFT HEIGHT:** 64" MAX
- TOWER:** 92" Height
- SAFETY DEVICES:**
 - Limit switches at each stop
 - Final limit switch at top
 - Non-skid platform surface
 - Tilt sensor (< 5%)
 - Obstruction sensing safety pan
 - Acme safety nut with monitor
 - Emergency manuel lowering
 - Emergency audible alarm
 - Electromechanical Interlocks
 - Platform main disconnect
 - 2252 keyed
 - Control operating panel with E-Stop (keyed 2252)
- EQUIPMENTS:**
 - Left hinged platform gate 36"
 - Right hinged platform gate 36"
 - (2) Call-stations mounted on the platform (keyed 2252)
 - Grab rail & Cab lights
- SAFETY DESING STDS:** ASME A18.1 section 2 vertical platform lift.
 - CSA B44.1 / ASME 17.5-elevator and escalator electrical equipment.
 - ICC A117.1 accessible and usable buildings and facilities(section 410)
 - Electrical number QAI: E10695

DRAWING FOR APPROBATION		
CHOOSER (✓)	APPROVED	
	APPROVED AS NOTED	
	RESUBMIT AS NOTED	
SIGNATURE		DATE
SIGN AND RETURNED		



NOTES:

- 1- Structural support by others. pad construction requirement may vary from state. dimensions given are atlas recommend clearances, reflecting running and access clearances. consult local authority to assure compliance with state and local codes.
- 2- Wall below top landing to be solid, smooth, plumb and square.
- 3- Any alterations to equipment without written authorization by atlas will void warranties.
- 4- Per ASME A18.1 the runway shall be guarded at the upper landing by door or gate at least 42"(1067mm) high of solid construction and provided with a combination mechanical lock and electric contact. the door shall be permitted to be opened only if the platform floor is withing 2"(50mm)of that landing.

AMERIGLIDE
 5110 Atlantic Ave,
 Raleigh, NC 27616
 Tel:1 (800) 790-1635

www.ameriglide.com		REF: 2429-YA-A-210218		Code: B-355 2015 A18.1 2014	KONE ALLEGiant STADIUM	
AMERIGLIDE IS NOT RESPONSIBLE FOR THE STRUCTURAL DESIGN OF THE BUILDING AND ITS ABILITY TO SUPPORT THE ELEVATOR LOADS AND OR REACTIONS		ALL DRAWINGS ARE THE INTELLECTUAL PROPERTY OF AMERIGLIDE AND CANNOT BE COPIED OR MODIFIED WITHOUT PERMISSION		GUARD PANEL: 42" HEIGHT	No DRAWING: HERCULES PORTABLE 36x54	Rev: 0
X REV	MD BY	XXXX DESCRIPTION:	0000 DATE:	SCALE: ± 1/16"	Drafter: M. Debusschere	Date: 02-18-2021
				Status: APPROVAL	2/2	



Egyptian Theatre - IL

Alex Nerad
alex@egyptiantheatre.org

Reference: 20201229-164015658
Prepared: December 29, 2020
Expires: July 1, 2021
Prepared by: Karen Camacho
Accessibility Specialist
kcamacho@ascension-lift.com
+1 (520) 881-3993

Comments from Karen Camacho

3-5 weeks ARO

Standard Warranty: 10 years drive train / 4 years parts / 90 days labor

Does not include applicable tax

Products & Services

Item & Description	Quantity	Unit Price	Total
Virtuoso 5460 P	1	\$31,050.00	\$29,497.50 after 5% discount
Protege Lift 5442 P	1	\$23,300.00	\$22,135.00 after 5% discount
Freight - single crate - Central includes \$600.00 custom shipping crate	1	\$1,580.00	\$1,501.00 after 5% discount

Subtotals

One-time subtotal \$53,133.50
after \$2,796.50 discount

Total \$53,133.50

Purchase Terms

Check in advance Net 30 days upon approval

Questions? Contact me



Karen Camacho

Accessibility Specialist

kcamacho@ascension-lift.com

+1 (520) 881-3993

Ascension Wheelchair Lifts - a division of AGM

3526 E. Ft. Lowell Road

Tucson, Arizona 85716-1705

USA

March 10, 2021

Bill Nicklas, City Manager
City of DeKalb
164 E. Lincoln Highway
DeKalb, IL 60115

RE: City of DeKalb AIP Grant / Letter Agreement

Egyptian Theatre Executive Director Alex Nerad, (“Owner”) hereby acknowledges and agrees to the terms of that certain Resolution 2021-022 (“the Resolution”), approving of an \$4,314.00 AIP Grant for Egyptian Theatre, (“Owner”) for use at 135 N. Second St., DeKalb, Illinois (“the Property”), subject to the following provisions:

1. Given the small scope of the requested grant, the City waives formal compliance with the requirements of the AIP process except as outlined herein. The City also waives requirement of a promissory note or mortgage to secure the AIP Grant.
2. Payment of the AIP Grant shall be as a reimbursement to Owner, after Owner provides proof of incurring costs of not less than \$8,628.00 on renovation at the Property consisting of: Americans with Disabilities Act (ADA) compliance on the stage access wheelchair lift. The AIP Grant shall be in the amount which is the lesser of: a) \$4,314.00; or, b) the amount which is not more than 50% of the total project costs.
3. The Owner agrees to provide documentation of the project and incurred costs, inclusive of full lien waivers, invoices, and adequate evidence of payment, all in form and content acceptable to the City Manager or designee, prior to payment of the reimbursement.
4. The Owner agrees, as a condition of accepting the funds contemplated herein, to maintain the improvements funded by this AIP Grant for a period of not less than five (5) years. The AIP Grant funds provided herein shall be considered partially forgiven by 20% (1/5) each year on the anniversary of their payment to Owner, until fully forgiven on the fifth anniversary of such payment. Should Owner fail to maintain the improvements for the full five-year period, then Owner shall be responsible for reimbursing the City in an amount equivalent to the then-unforgiven portion of the AIP Grant (e.g. if the Owner fails to maintain the improvements in the 4th year, the Owner shall reimburse the City for forty percent (40%) of the AIP Grant amount.

5. The Owner agrees to indemnify, defend and hold harmless the City from any claims or damages arising out of or relating to the AIP Grant or the work to be performed by Owner. The Owner shall provide the City with a certificate of insurance naming the City as additional primary insured with waiver of right of subrogation prior to commencement of work. The Owner agrees and acknowledges that the funding contemplated herein is payable to Owner only and may not be assigned or transferred to any other party. The City shall not make direct payments to any contractors or materialmen, and the City's obligation to provide funding shall not accrue until Owner provides the City with evidence of lien waivers from all contractors and materialmen providing labor or materials for the project.
6. The Owner shall complete all related work in a good and workmanlike fashion, in accordance with all applicable codes and ordinances, and after having obtained all required permits. All work shall be subject to inspection and approval by the City, once completed.
7. All work shall be completed within one calendar year of the date of approval of this Resolution, or the funding approval contemplated herein shall terminate and this Resolution shall be of no further force or effect.
8. Owner shall provide a letter to the City, acknowledging and agreeing to the terms and conditions of this Resolution, prior to the City's issuance of payment to Owner.

Agreed to as of the 10 day of March . 2021.



Alex Nerad, Executive Director

